

Amphenol Antenna Solutions



**APM50-B2 MOUNTING KIT
INSTALLATION INSTRUCTIONS**

REV. 3.0 | 2023.09

Mounting Instructions for APM50-B2 Kit

SUMMARY

- 1. Applications.....3
- 2. Mechanical Specifications3
- 3. Assembly and Installation3
 - Installation Preparation.....3
 - Installation Tools3
 - Installation Instructions.....4
- 4. Antenna Mechanical Downtilt Range.....5
- 5. Material list.....6

Mounting Instructions for APM50-B2 Kit

1. APPLICATIONS

The APM50 kits are mounting hardware options to be used for Base Station antennas.

2. MECHANICAL SPECIFICATIONS

- Pole Diameter: 60-110 mm
- Weight: 4.5 kg

3. ASSEMBLY AND INSTALLATION

Installation Preparation

1. Check each package against packing list.
2. Observe safe working at heights.
3. Ensure lightning protection is applied.
4. Annual maintenance is recommended to antenna system.

Installation Tools

TIGHTENING NUT TORQUE VALUES

TIGHTENING CONNECTOR TORQUE VALUES

Nut	Wrench	Torque	Connector	Wrench
M8	13(14)mm	18-22Nm	4.3-10	5-8Nm
M10	16(17)mm	32-40Nm	7-16	18-22Nm

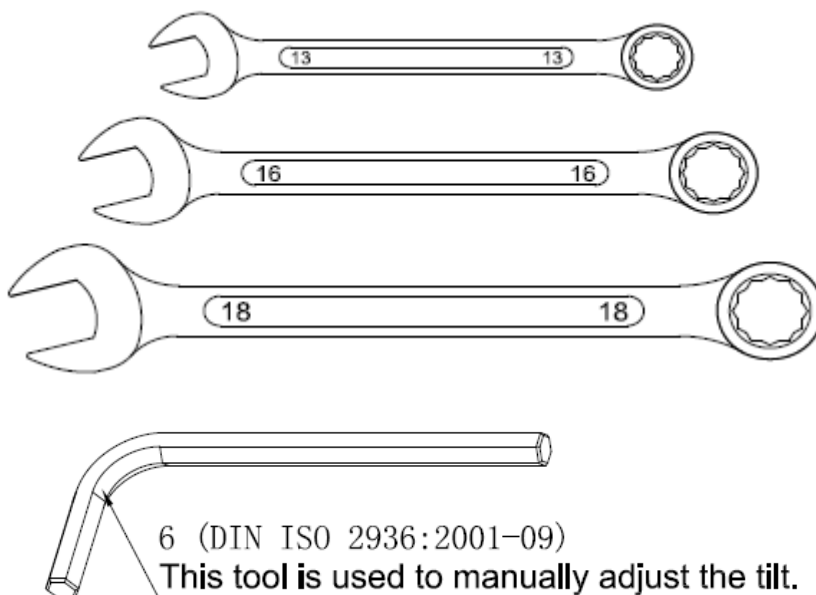

Mounting Instructions for APM50-B2 Kit

Installation Instructions

Step 1

Pre-assemble the top and bottom mounting brackets. Tighten the U Clamp with M8 bolts (torque 18Nm).

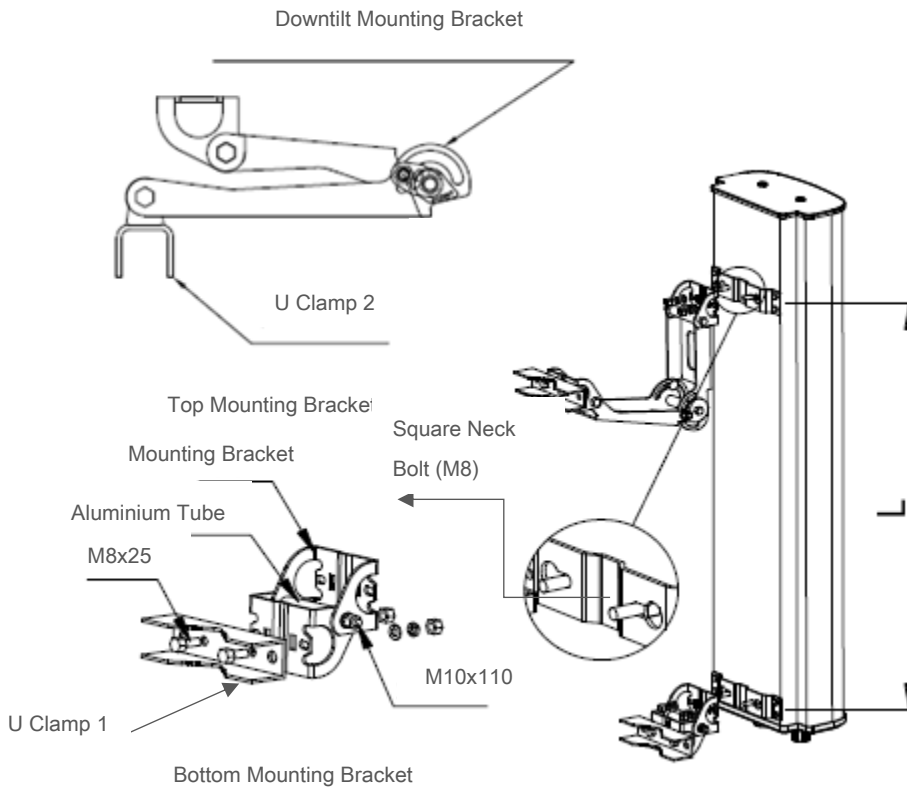

Step 2

Assemble mounting brackets to the antenna with four M8 bolts (torque 18Nm).

Step 3

1. Adjust tilt to 0° and tighten nut A;
2. Fasten antenna to pole vertically with M10x150 bolts (torque 32Nm).

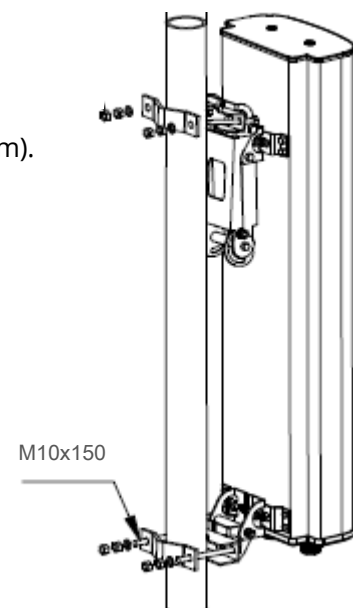

Mounting Instructions for APM50-B2 Kit

Step 4

Loose nut A and adjust downtilt mounting bracket to achieve required downtilt angle.

Step 5

Tighten nut A and B to fix antenna downtilt angle (torque 32Nm).

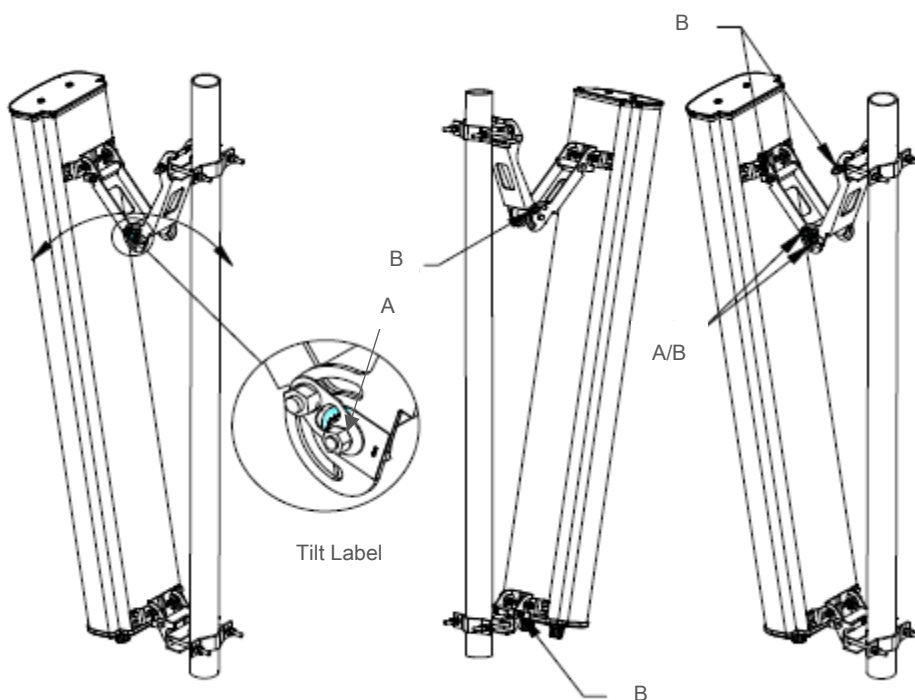

4. ANTENNA MECHANICAL DOWNTILT RANGE

Antenna Length (mm)	Mechanical Downtilt Range (°)
2900	0-7
2520	0-8
2100	0-9
1450	0-12
1365	0-13
1250	0-14
1088	0-16
920	0-20
558	0-30

Mounting Instructions for APM50-B2 Kit

5. MATERIAL LIST

ITEM#	DESCRIPTION	QTY
1	0534701 Bracket 1	1
2	0534702 Bracket 1	1
3	052103 Mounting Bracket	4
4	052104 Aluminium Tube	4
5	057304 C Clamp	2
6	052105 U Clamp	2
7	Hex Bolt (M10x150)	4
8	Hex Bolt (M10x110)	4
9	Square Neck Bolt (M10x30)	2
10	Square Neck Bolt (M8x25)	4
11	Nut (M10)	14
12	Nut (M8)	8
13	Plain Washer (M10)	10
14	Plain Washer (M8)	8
15	Spring Washer (M10)	6
16	Spring Washer (M8)	8
17	052007 Tilt Indicator	1
18	0521709 Tilt Label	1
19	Hex Bolt (M8x25)	4

Mounting Instructions for APM50-B2 Kit

NAR

Conover & Meriden
+1 (779) 970-1605
Technical Support

support@amphenol-antennas.com

APAC

Shanghai
+86 (21) 3773 8888
Technical Support

apac.bsa.support@amphenol-antennas.com

EMEA & LATAM

Amboise & Lannion

Technical Support

techsupport@amphenol-antennas.com